

BELLALUZ COMMUNITY

Application for Committee Approval of Proposals for

Installation of or Changes to any Items in the following categories. Windows, External Doors, Air-Con Units, Cables, Buildings, Terraces, Toldos, in fact anything affecting the Exterior of an Owner's Property or any other Common Elements. This includes dispensing and other machines, televisions, parasols, gazebos, etc.

To: The Administrator

From: Owners Name: BERNARD CAHILL Property No: B-02

Current Address: BELLALUZ 18.02

Phone/Fax No: 633115619 e-mail: CAHILL.BERNARD@EMAIL.COM

Description of Proposal (Attach documents, photos, drawings, etc.)

- ① ~~INSTALL~~ ^{ERECT} STORAGE CABINETS TO FRONT OF PROPERTY. 1.40 X 0.90 X 2.25.
- ② ~~ERECT~~ ^{EXTEND} CURRENT STORAGE CABINETS TO REAR OF PROPERTY. 0.94 X 0.65 X 1.54
- ③ INSTALL GLASS CURTAINS TO REAR OF PROPERTY, WITHIN THE FOOTPRINT OF THE OVERHANG OF THE UPSTAIRS APARTMENT. 3.00 X 0.90 X 2.50

1. I enclose 2 copies of sketches, plans and drawings as appropriate.
2. I confirm that all legal consents, planning approvals and licences required will be applied for before work commences (where applicable).
3. I undertake to ensure that the contractor conforms to the Site Rules and Regulations issued by the Bellaluz Community (where applicable).
4. I understand that all work for which approval is sought is subject to an on-site review by the President of my Community.
5. I undertake to ensure the clean-up and restoration of any surrounding area that has been affected by the proposed work.
6. I confirm that I have read and understand the "Bellaluz Regulations & Guidelines" issued by the Bellaluz Community and undertake to comply fully with these and any conditions applied by my Community President as indicated below.

Owner's Signature: Bernard Cahill Date: 15-03-2018

This Application has been considered at the Committee Meeting held on: _____ (where applicable)

Application: Approved/Rejected

All Approvals other than changes to buildings are UNTIL FURTHER NOTICE (to take account of depreciation, changing circumstances, etc.) Approvals lapse after 12 months if changes are not made and reapplication will be necessary.

Conditions or Comments: _____

Signed: _____ President (for the Committee) Date: _____

Signed: _____ Administrator Date: _____

①

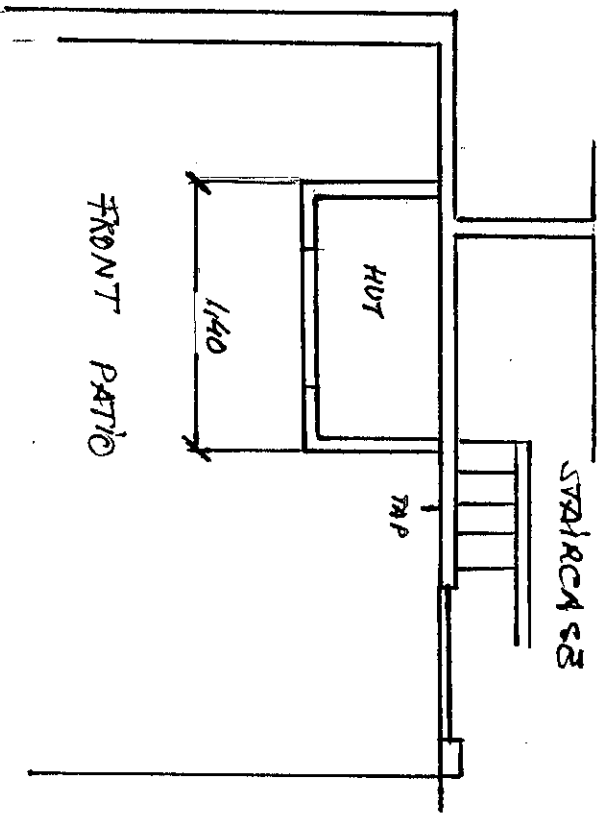
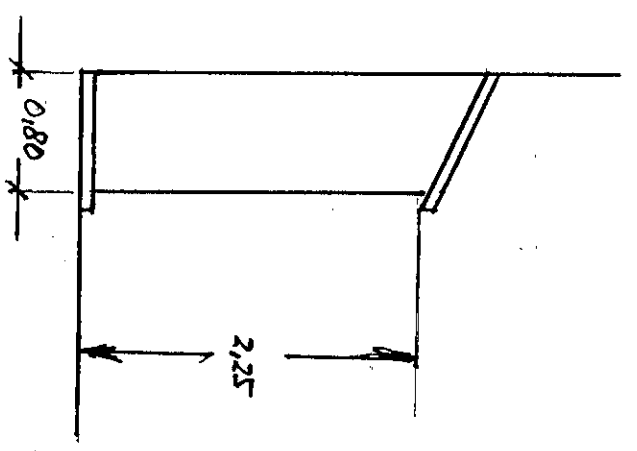
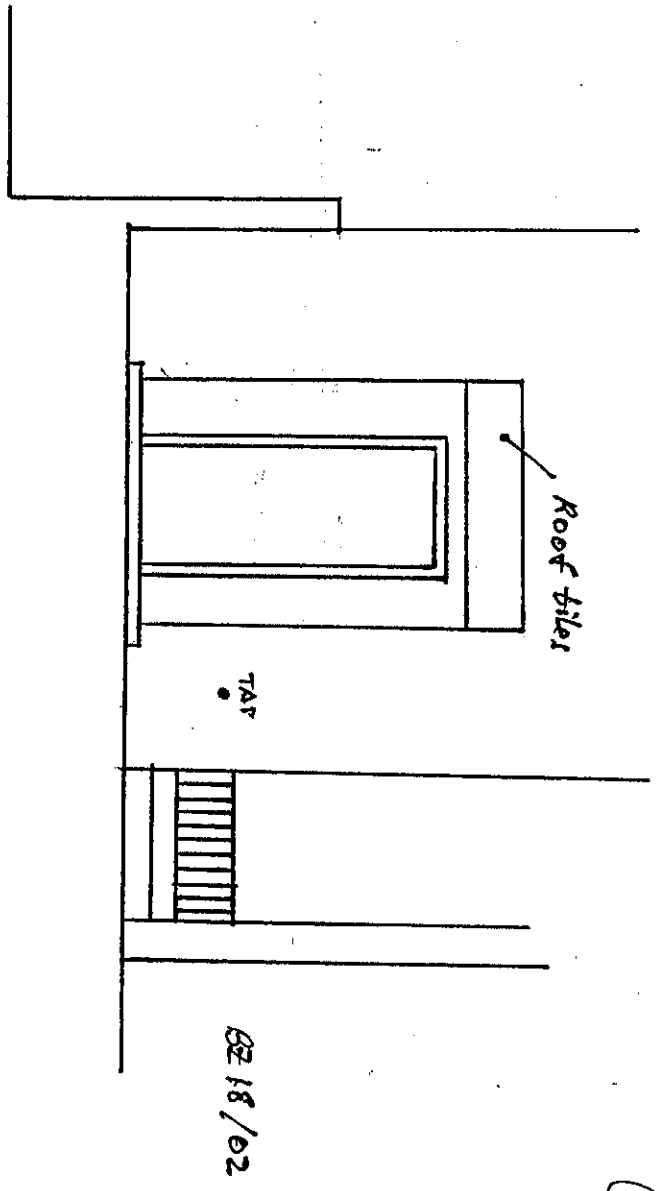

2.1

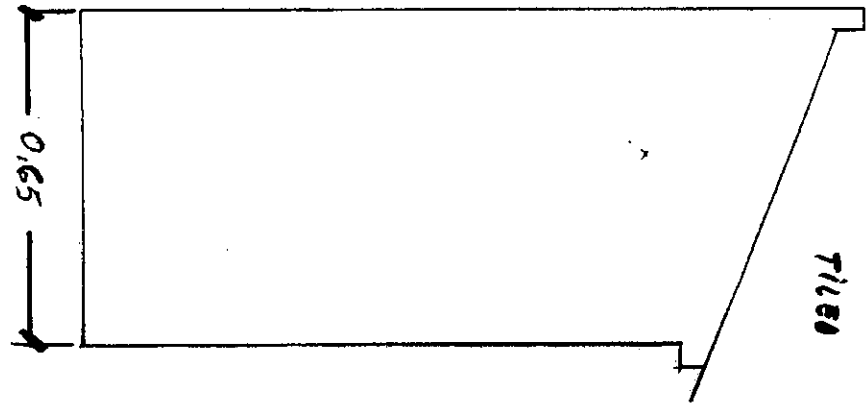
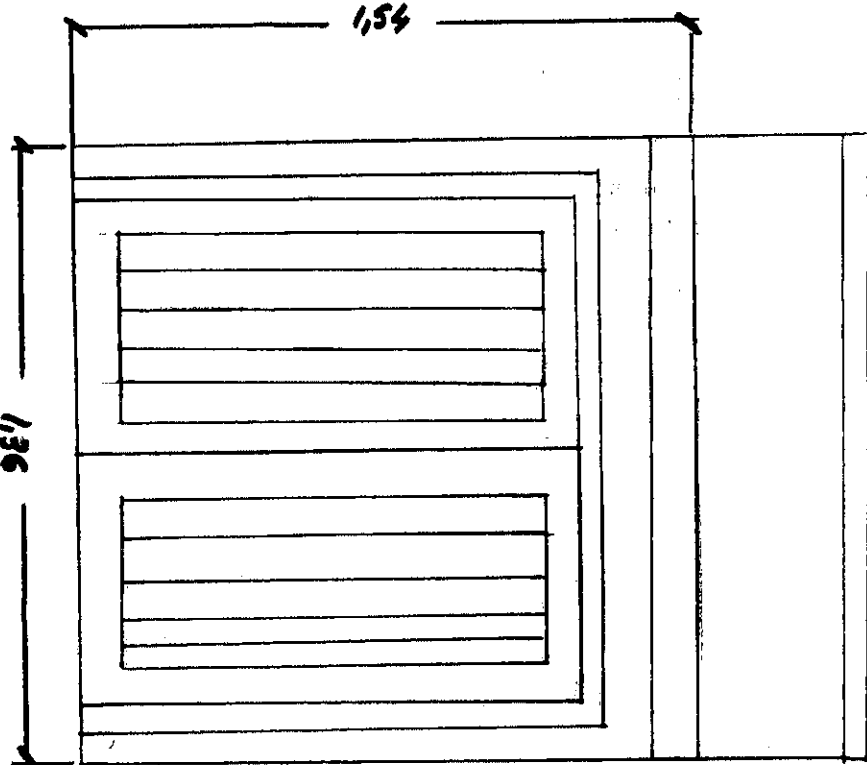

ACTUAL STATE

PROPOSAL

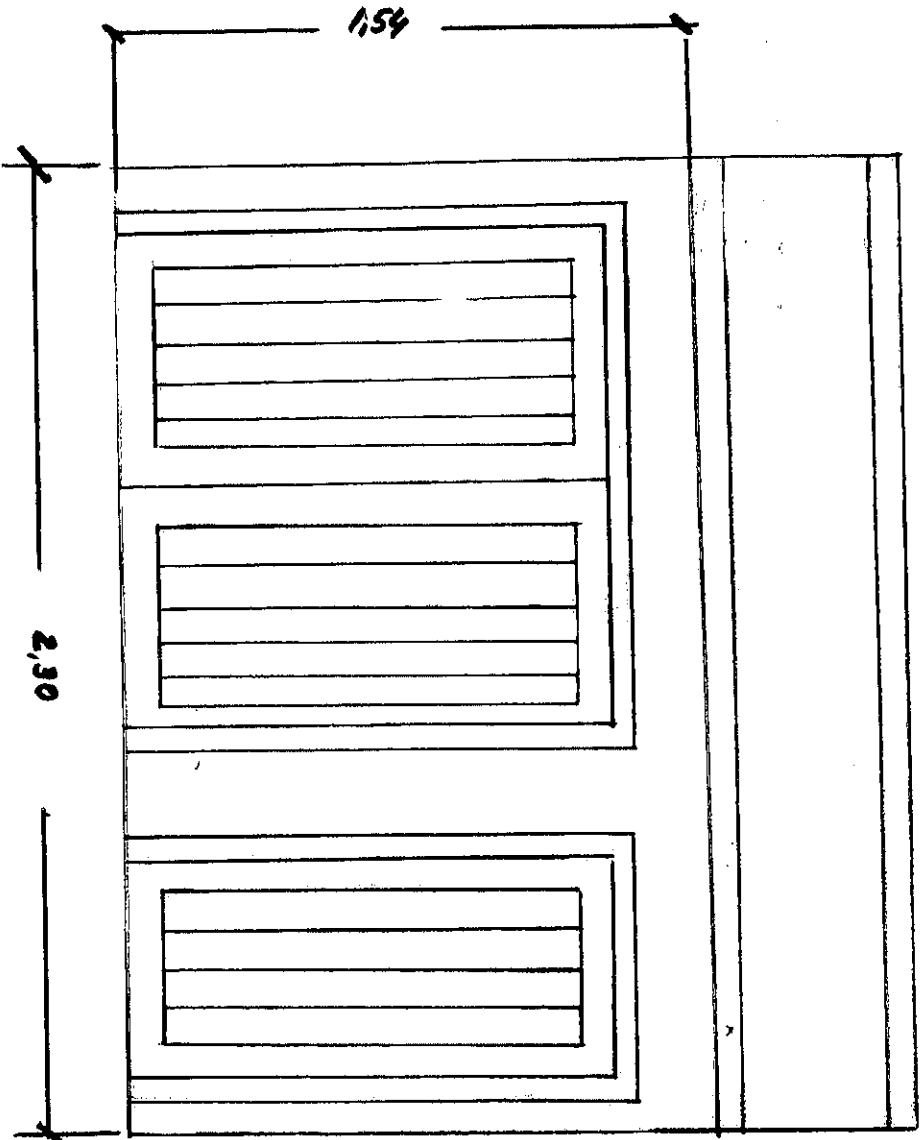

2.2

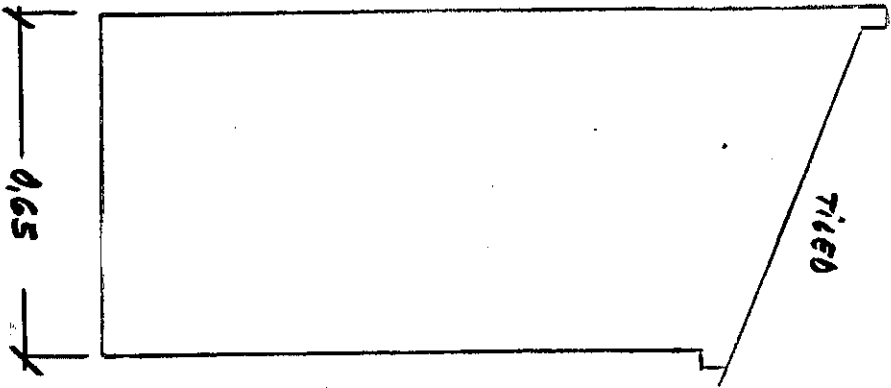

ACTUAL

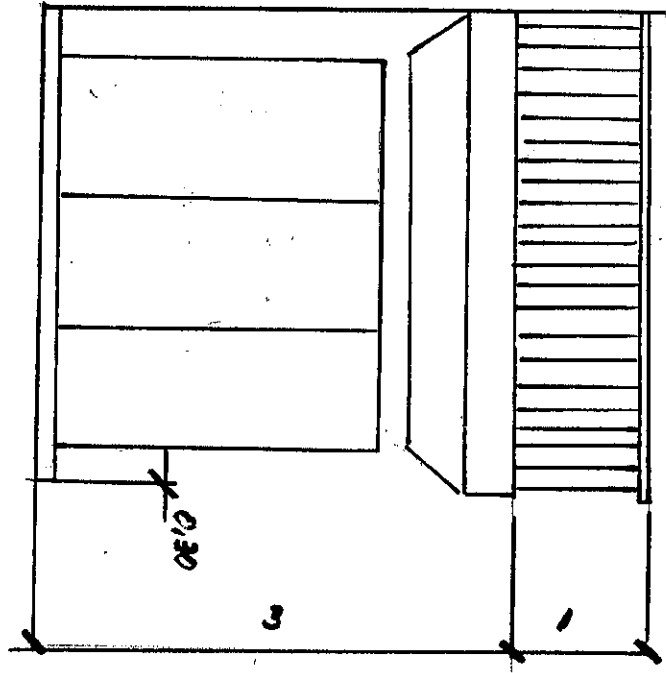

PROPOSED

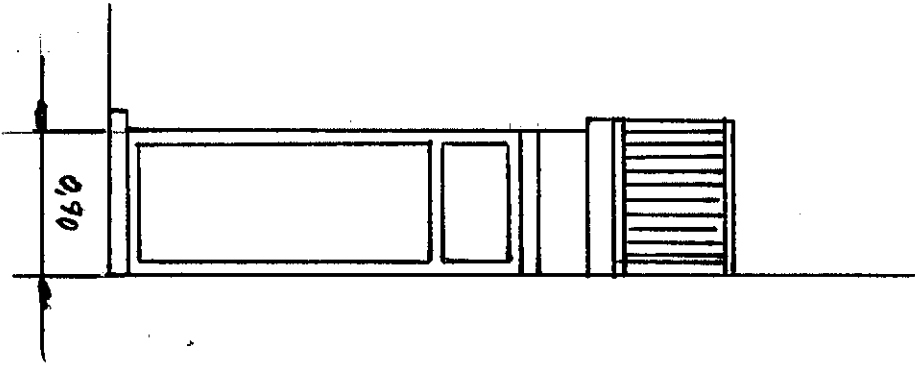
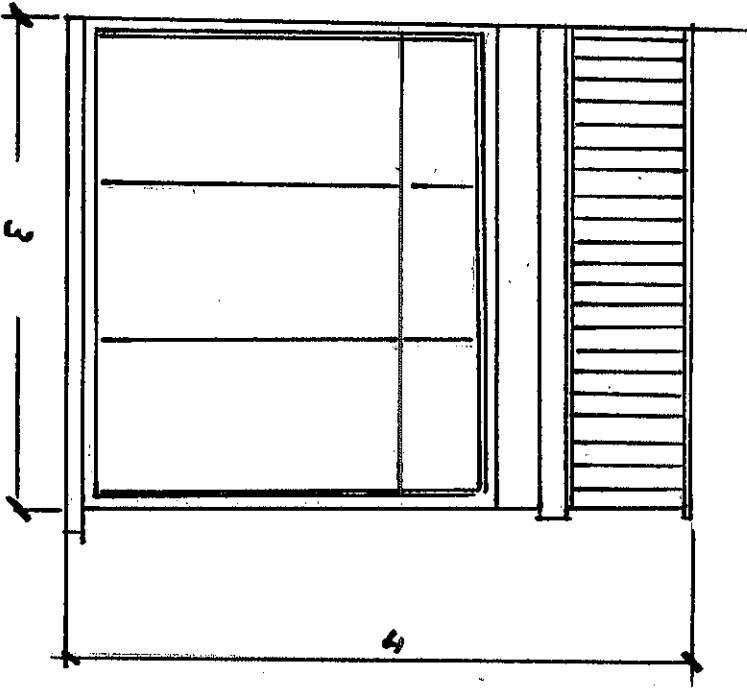

3